



एमएसएमईपरीक्षणकेन्द्र (प.क्षे),

सूक्ष्म, लघु एवं मध्यम उद्यम मंत्रालय,

भारत सरकार,

कुर्ला-अंधेरी रोड, साकीनाका, मुम्बई - 400 072.

टेलीफोन: 022 - 28570588, 28576998

फैक्स : 022 - 28572238.

e-mail : dctc-wr@dcm sme.gov.in

MSME TESTING CENTRE (W.R),

Ministry of Micro, Small & Medium Enterprises,

Government of India,

Kurla Andheri Road, Saki Naka,

Mumbai - 400 072.

Tel.: 022 - 28570588, 28576998

Fax: 022 - 28572238.

Web: www.msme tc mumbai.gov.in



परीक्षण रिपोर्ट

TEST REPORT

रिपोर्ट संख्या / Report No	जारी करने की तिथि / Date of Issue	कुल पृष्ठ संख्या / Total Page Nos.
MSMETC-WR/EL/218/11/2019-20	13.01.2020	03
1. कार्य संख्या / Job Order No.	CSC/EL/218-221/11/2019-20	
2. तिथि / Date	18.11.2019	
C U S T O M E R	3. नाम / M/s.	Unique Diecasting Products Pvt. Ltd.
	4. पता / Address	M/s. Unique Diecasting Products Pvt. Ltd., A/569, T.T.C. Industrial Area M.I.D.C., Mahape, New Mumbai
	5. अनुरोध पत्र संख्या / Request Letter No.	UDP-MSME-02
	6. तिथि / Date	16.11.2019
	7. सैंपल प्राप्त का दिनांक / Date of receipt of sample	18.11.2019
	8. सैंपल की स्थिति / Condition of the sample(s)	Suitable for testing
	9. सैंपल-कोड / Sample Code (if any)	-----
	10. टी.आर.5 संख्या / T. R. 5 No.	2405
तिथि / Date:	18.11.2019	
11. द्वारा जारी / Issued by :	<p>Signature A. G. TELANG 13.01.2020 A. G. TELANG Asstt. Director (MET.) MSME Testing Centre (WR) Min. of MSME, Govt. of India Mumbai-400 072.</p>	

- N.B.:**
1. This report pertains to the particular sample submitted for test.
 2. This report shall not be reproduced in part or full.
 3. The Test / Calibration Report shall not be used for Legal purpose and shall not be produced in the court of law.
 4. Tested sample(s) should be collected within 30 days from issue of this report failing which no claim whatsoever & no correspondence in matter shall be entertained and such samples(s) will be disposed as per Govt. Procedure.
 5. Full / Part Tests covered / Tests not covered under NABL Accredited scope.

टेस्ट रिपोर्ट/Test Report



रिपोर्ट नं./Report No. : MSMETC-WR/EL/218/11/2019-20
दिनांक /Date : 18.11.2019
सैम्पल - विवरण /
Sample Description : Mini Thermocouple head (UDP-MTB
-02112019 & UDP-MTC-02112019)
मात्रा /Quantity: : 1 No.
किया गया परीक्षण /
Test Conducted : Degree of Protection IP 68 & External Dimension.
परीक्षण विशिष्ट /
Test Specification : IS/IEC -60529:2001 Standard Specification for Degree of
protection provided by Enclosures(IP Code) &
As per Customer's Requirement
मानक का संशोधन, यदि कोई हो : Nil
Amendment of Standards, if any
परीक्षण प्रारंभ दिनांक/
Test Commencement Date : 02.01.2020
परीक्षण पूरा होने का दिनांक / Test
Completion Date : 03.01.2020

परिणाम / Results

संख्या Sr. No.	परीक्षण विवरण Test Description	मानक विशिष्ट Standard Specification	परीक्षण परिणाम Test Results	टिप्पणी Remarks
1 1.1	Degree of Protection IP-68 Test Degree of Protection Against Solid Foreign Object (Dust Tight Test) (IP 6X) (1 st Characteristic Numerals) (Cl. 5.2, Table 2 & Table 7) Test conducted as per Cl.13.4 of IS/IEC -60529:2001	Shall not observe deposit of Dust inside the enclosure at the end of the test	No deposit of dust observed inside the enclosure after the test.	Satisfactory

द्वारा जारी :

Issued by:

प्राधिकृत हस्ताक्षरकर्ता :

Authorized Signatory

18/11/2020

(Manoj Khunekar)

Asst. Director (Elect.)

Report No. : MSMETC-WR/EL/218/11/2019-20

परिणाम / Results



क्रम संख्या Sr. No.	परीक्षण विवरण Test Description	मानक विशिष्ट Standard Specification	परीक्षण परिणाम Test Results	टिप्पणी Remarks
1.2	<p>Degree of Protection Against Water (IP X8): (2nd Characteristic) (Cl.6, Table 3 & Table 8) <u>Protected against the effects of continuous immersion in water</u> Test conducted as per Cl.14.2.8 by completely immersing the equipment in water for the duration of 2 hrs. (As per customer's requirement)</p>	<p>Should not ingress water in quantities causing harmful effects when the enclosure is continuously immersed in water</p> <p>If any water has entered, it should not i) be sufficient to interfere with the correct operation of the equipment or impair safety ii) Deposit on insulation parts where it could lead to tracking along the creepage distances. iii) Reach live parts or winding not designed to operate when wet iv) Accumulate near the cable end or enter the cable if any</p>	<p>No ingress of water observed that would cause harmful effect</p>	<p>Satisfactory</p>
2	<p>External Dimension (As per Customer's Requirement)</p>	<p>Should be as per drawing no.UDP-MTB-02112019 and UDP-MTC-02112019</p>	<p>Verified Outer dimension. Compliance as per drawing no. UDP-MTB-02112019 and UDP-MTC-02112019</p>	<p>Satisfactory</p>
<p>General Remarks : The sample meets the requirements of IS/IEC -60529:2001 specification and Customer's requirement With respect to the test carried out.</p>				

द्वारा जारी :

Issued by:

प्राधिकृत हस्ताक्षरकर्ता :

Authorized Signatory

15/11/20

(Manoj Khunekar)

Asst. Director (Elect.)

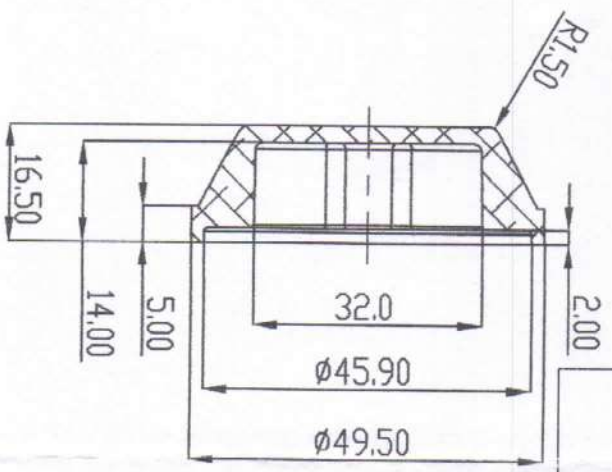
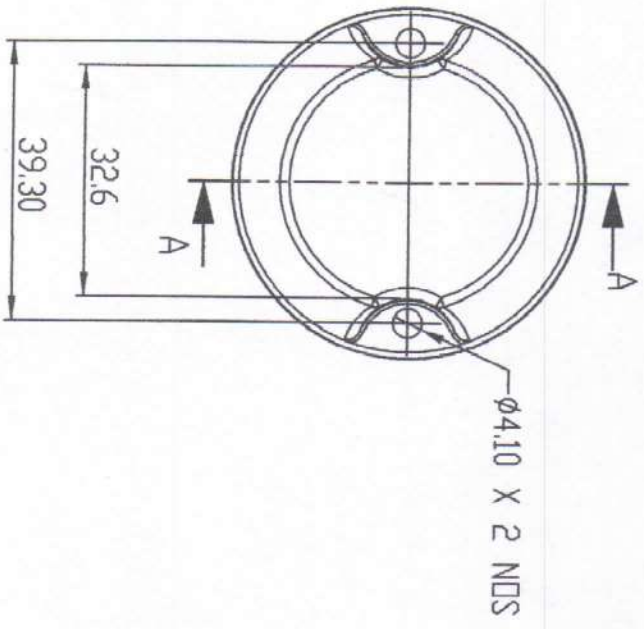



SECTION A-A

MSME TESTING CENTRE MUMBAI
 Report No.: MSMETC-WR/EL/218/11/2019-20
 Verified Outer Dimension

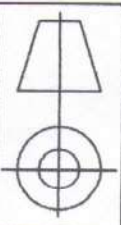

Manoj Khunekar
 13/11/20

(Manoj Khunekar)
 Asst. Director (Electr.)

				UNIQUE DIECASTINGS PRODUCT PVT. LTD.	
DATE	13-06-2019	TITLE:-	MINI THERMOCOUPLE COVER		
DRAWN BY	RAHUL	DRAWING NO:-	UDP-MTC-02112019	ALL DIMENSION ARE IN MM	REVISION:-00
APPROVED BY	RAJESH	SHEET NO	SCALE	SCALE	SCALE
MATERIAL					
WEIGHT					

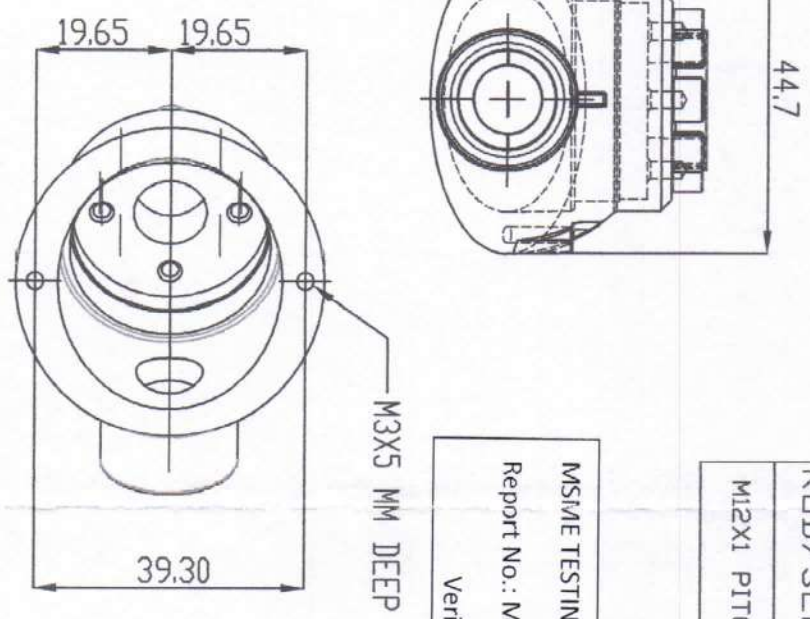
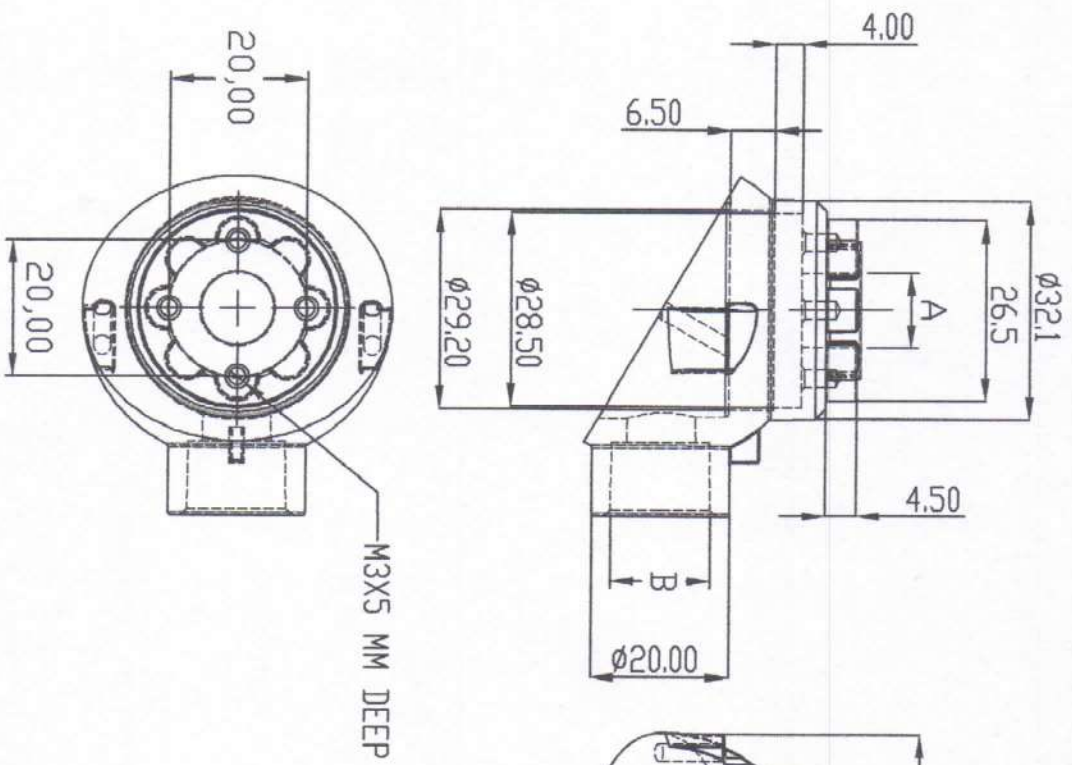

A	B
RDD/SENSOR	CABLE
M12X1 PITCH	M16X1,5 PITCH

MSME TESTING CENTRE MUMBAI
 Report No.: MSMETC-WR/EL/218/11/2019-20
 Verified Outer Dimension

(Manoj Khunekar)
 Asst. Director (Elect.)

Manoj
 13/11/20

DATE	02-10-2019		TITLE	MINI THERMOCOUPLE BODY
DRAWN	RAHUL		DWG NO.	UDP-MTB-02112019
CHK'D	RAJESH V.		SCALE	
APPV'D	ND		REVISION NO.: 00	
MATERIAL:				
WEIGHT:				

UNIQUE DIECASTING
 PRODUCTS PVT. LTD.

UDP-MTB-02112019

A4

SHEET 1 OF 1